

# Prop S Technology Integration



# Three Major Areas

- 7000 *i-21* Integrated Classrooms
- Infrastructure
  - Campus wireless at all schools
  - Wired infrastructure at middle schools
  - Switch upgrades at all schools
- Data Center





# What is *i-21*?

The 21<sup>st</sup> Century (*i-21*) Interactive Classroom is an engaging interconnected learning environment designed to optimize student access and participation by integrating mobile computing, audio, visual and formative assessment technologies across the curriculum. The *i-21* classroom is both relevant and advanced in technology implementation while also maximizing flexibility and providing just-in-time functionality for student learning.

# Four *i-21* Configurations

- Grades K-2
- Grade 3
- Grades 4-5
- Grades 6-12





# Grades K-2 Room Layout

Grades K - 2

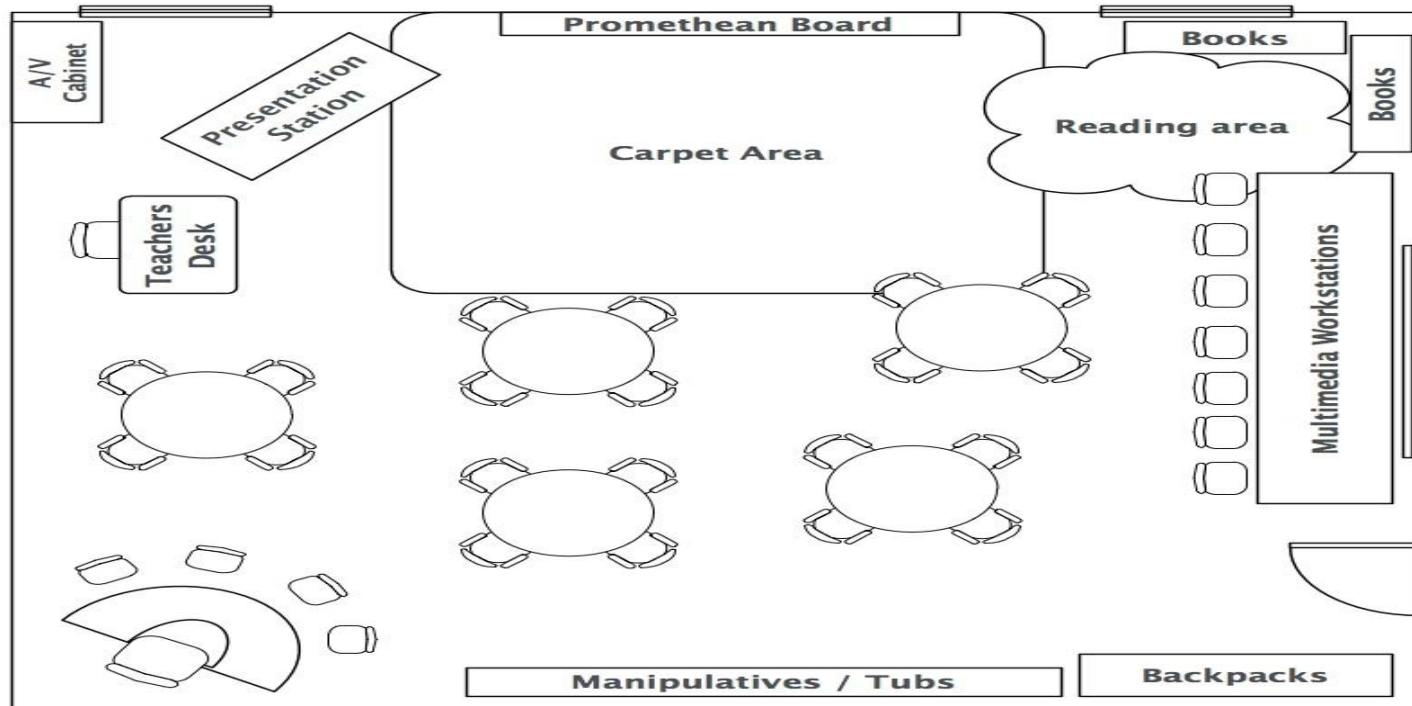

# Grades K-2 Inventory

<b>QTY</b>	<b>Description</b>
1	Interactive white board
1	LightSpeed sound system
7	Network terminals
1	Class set responders
7	Licensing
1	Network printer
1	Teacher work station
1	Doc cam



# Grades 3 Room Layout

Grade 3  
Collaborative configuration

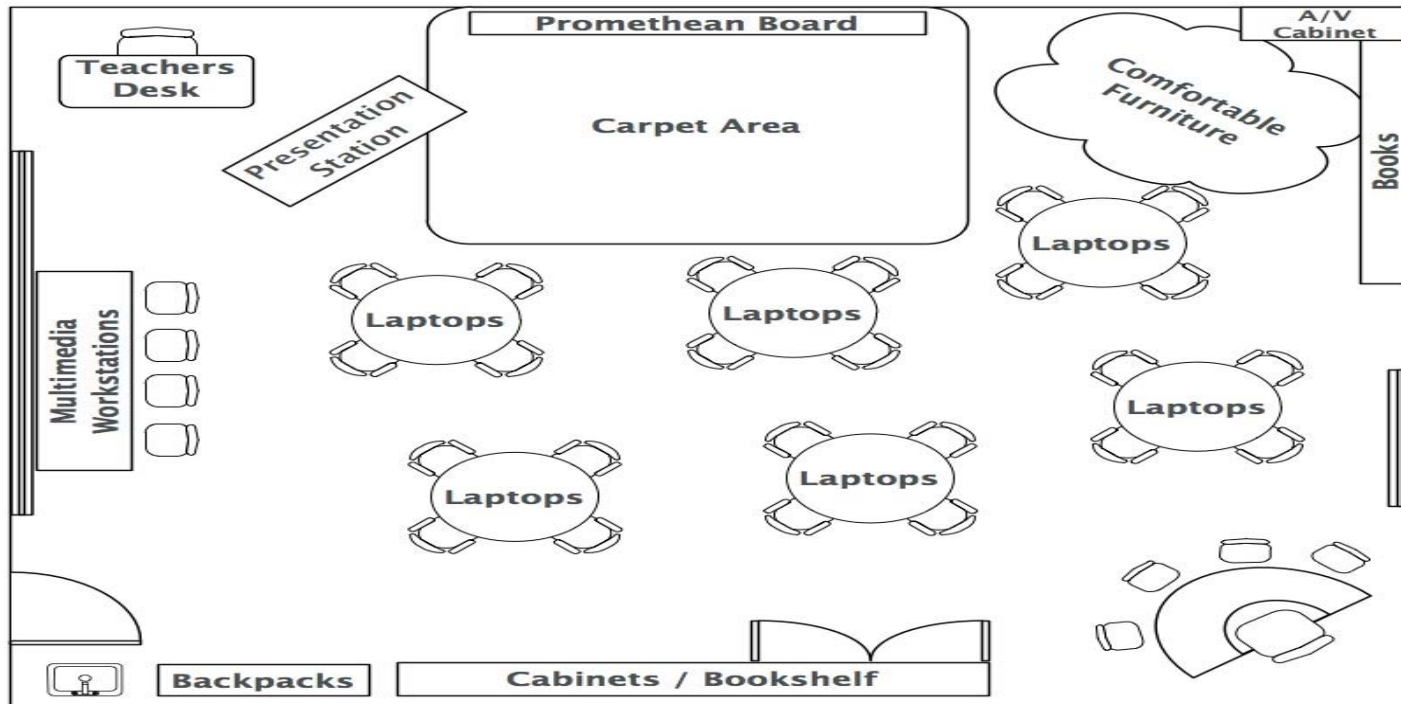



# Grade 3 Inventory



<b>QTY</b>	<b>Description</b>
1	Interactive white board
1	LightSpeed sound system
21	Netbooks
21	Licensing
1	Network printer
1	Teacher work station
1	Doc cam
1	Cart Bretford 32



# Grades 4-5 Room Layout

Grades 4-5 (34 Students)  
Flexible collaborative configuration

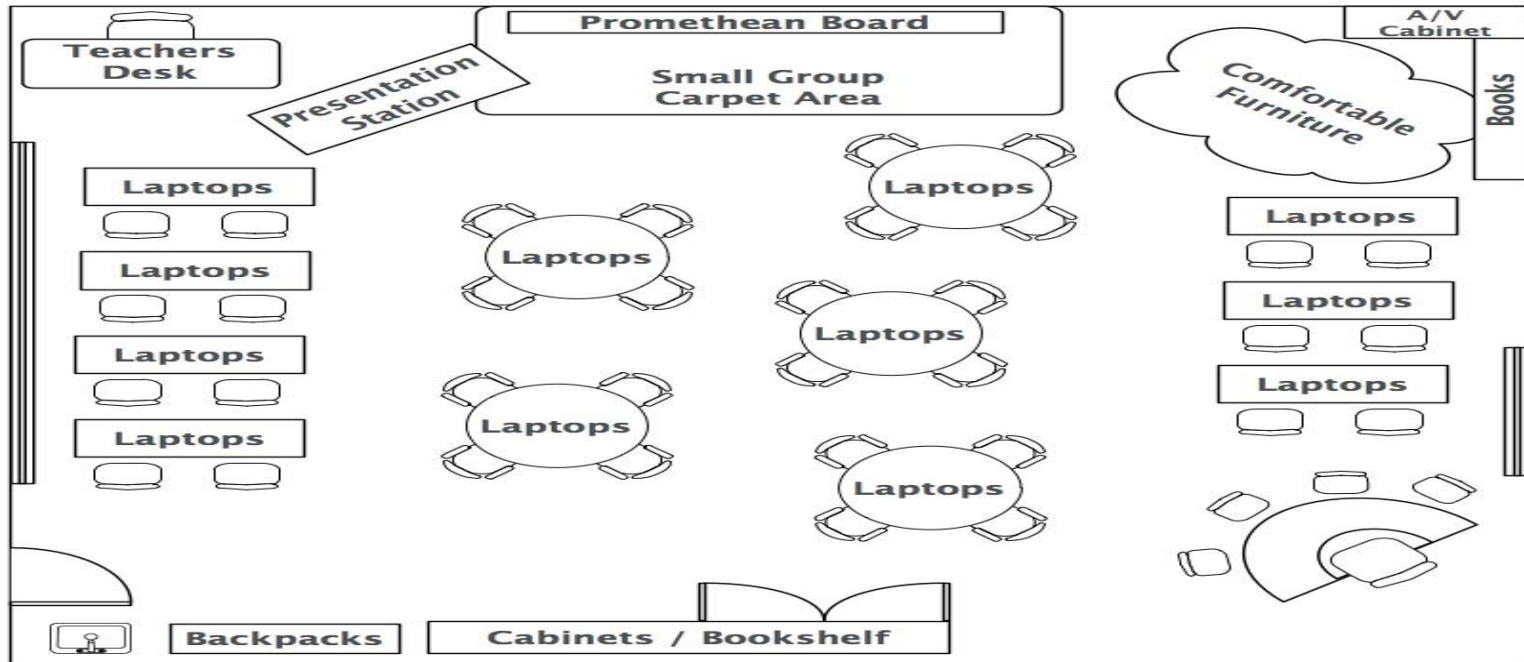

# Grades 4-5 Inventory

<b>QTY</b>	<b>Description</b>
<b>1</b>	Interactive white board
<b>1</b>	LightSpeed sound system
<b>34</b>	Netbooks
<b>34</b>	Licensing
<b>1</b>	Network printer
<b>1</b>	Teacher work station
<b>1</b>	Doc cam
<b>1</b>	Cart Bretford 32



# Grades 6-12 Layout

Grades 6-12 (32 Students)  
Flexible collaborative configuration

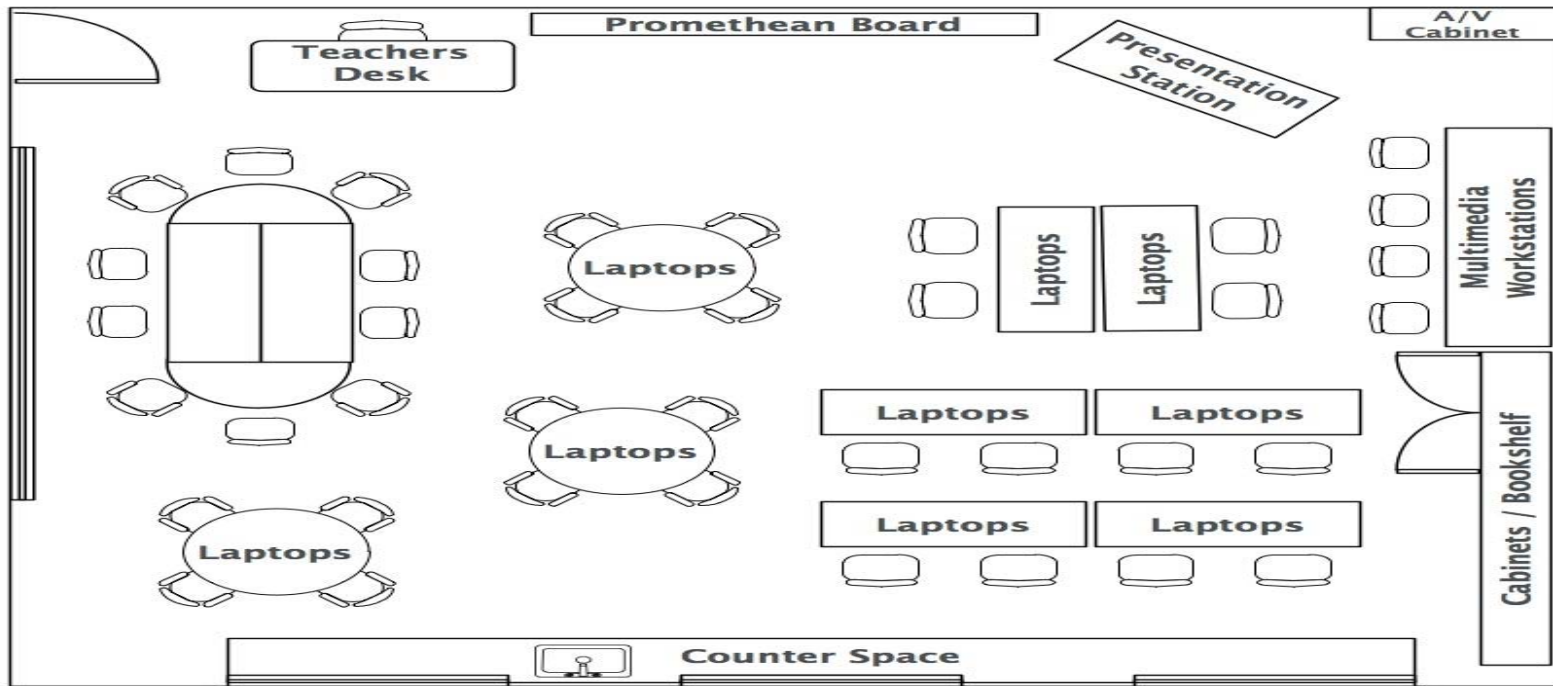

Flexible Furniture Options

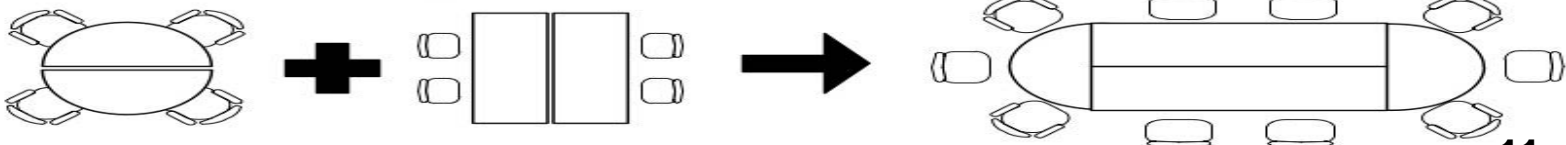



# Grades 7-12 Inventory

QTY	Description
1	Interactive white board
1	LightSpeed sound system
34	Netbooks <b>W/3G</b>
34	Licensing
1	Network printer
1	Teacher work station
1	Doc cam
1	Cart Bretford 32

# *i-21* Professional Development

- ORGANIZED TO PROVIDE TEACHERS A TRAINING SEQUENCE THAT IS CLOSELY CONNECTED TO THE WORK OF THE CLASSROOM
- DEVELOPS A SUSTAINING LEVEL OF EXPERTISE AND CAPACITY AT EACH SCHOOL SITE
- UTILIZES ONLINE RESOURCES TO SUPPLEMENT FACE-TO-FACE TRAINING



# *i-21* Professional Development (key components)

- Interactive white board training
- Computer integration training
- Develop teacher-experts at site
- Site-based user groups
- Develop site success plan
- Check-up at 6 months
- Online resources aligned to curricula



# Infrastructure Wireless

- Campus-wide wireless networks

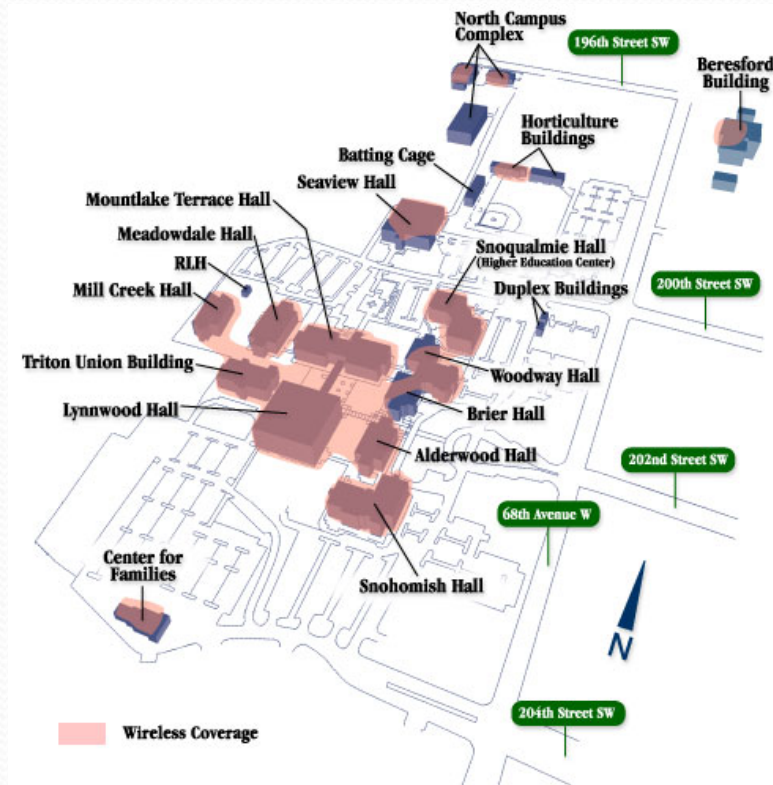

# Wired Upgrades

- 22 middle schools

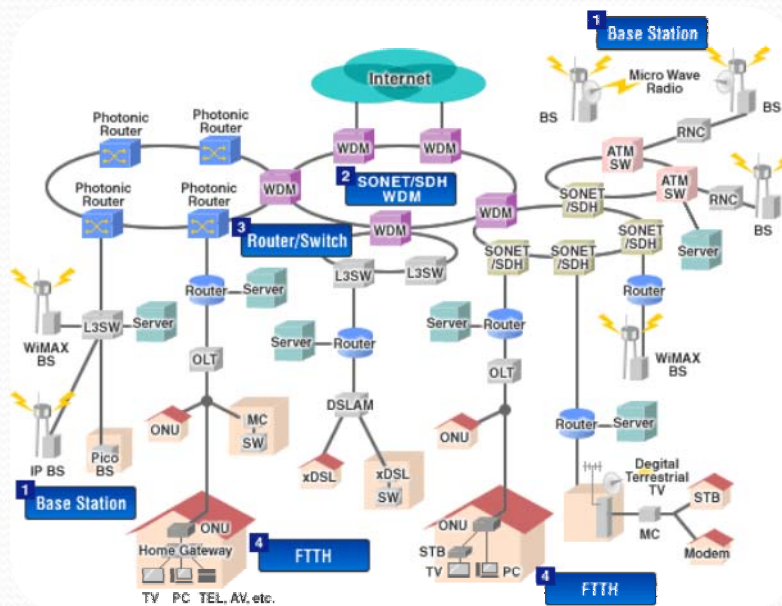



# Switch Upgrades

- 126 elementary schools
- 16 comprehensive high schools

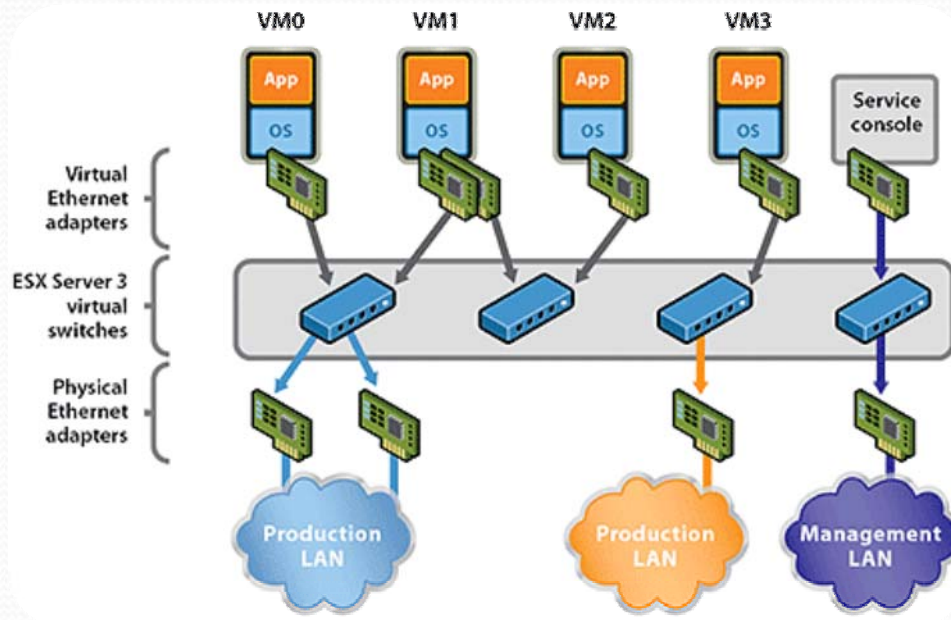



# Data Center

- 5000 square feet for equipment
  - 50 servers
  - 500 terabyte of storage
- 2500 square feet office and open area
- 2 classrooms
- Integrates Multiple Pathway Program

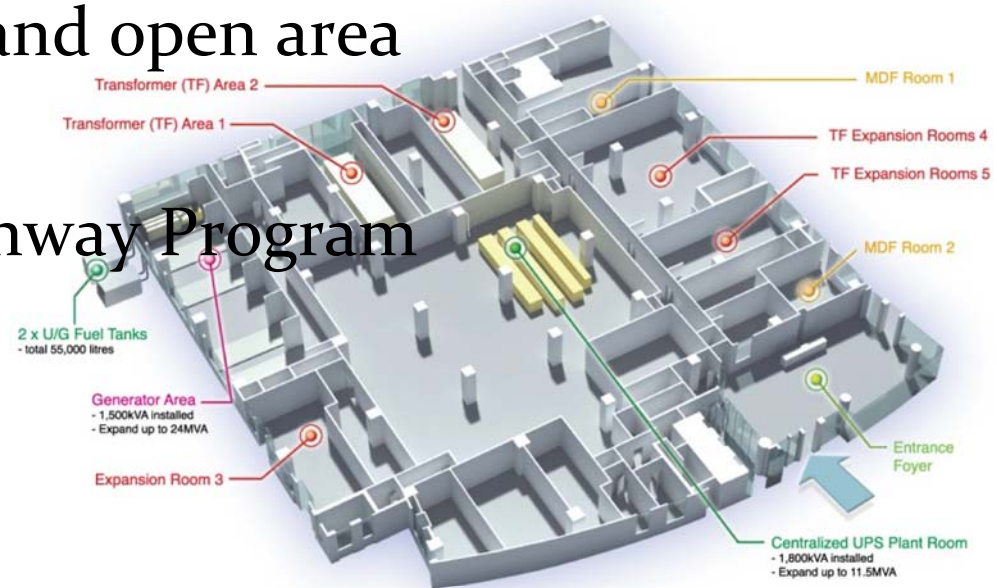

# K-2 Estimated Equipment Costs

QTY	Description	Cost	Total
1	Interactive white board	3,999.95	3,999.95
1	LightSpeed sound system	1,090.00	1,090.00
7	Network terminals	485.00	3,395.00
1	Class set responders	1,599.00	1,599.00
7	Licensing	70.00	490.00
1	Network printer	969.00	969.00
1	Teacher work station	1,271.00	1,271.00
1	Doc cam	642.00	642.00
			13,455.95
	Tax		1,177.40
1	Typical installation	1,056.00	1,056.00
1	Training	500.00	500.00
	<b>Total</b>		<b>16,189.35</b>



# 3rd Estimated Equipment Costs

QTY	Description	Cost	Total
1	Interactive white board	3,999.95	3,999.95
1	LightSpeed sound system	1,090.00	1,090.00
21	Netbooks	383.50	8,053.50
21	Licensing	70.00	1,470.00
1	Network printer	969.00	969.00
1	Teacher work station	1,271.00	1,271.00
1	Doc cam	642.00	642.00
1	Cart Bretford 32	1,182.00	1,182.00
			18,677.45
	Tax		1,634.28
1	Typical installation	1,056.00	1,056.00
1	Training	500.00	500.00
	<b>Total</b>		<b>21,867.73</b>



# 4-5 Estimated Equipment Costs

QTY	Description	Cost	Total
1	Interactive white board	3,495.95	3,495.95
1	LightSpeed sound system	1,090.00	1,090.00
34	Netbooks	383.50	13,039.00
34	Licensing	70.00	2,380.00
1	Network printer	969.00	969.00
1	Teacher work station	1,271.00	1,271.00
1	Doc cam	642.00	642.00
1	Cart Bretford 32	1,182.00	1,182.00
			24,068.95
	Tax		2,106.03
1	Typical installation	994.00	994.00
1	Training	500.00	500.00
	<b>Total</b>		<b>27,668.98</b>

# 6-12 Estimated Equipment Costs

QTY	Description	Cost	Total
1	Interactive white board	3,999.95	3,999.95
1	LightSpeed sound system	1,090.00	1,090.00
34	Netbooks w/3G	485.50	16,507.00
34	Licensing	70.00	2,380.00
1	Network printer	969.00	969.00
1	Teacher work station	1,271.00	1,271.00
1	Doc cam	642.00	642.00
1	Cart Bretford 32	1,182.00	1,182.00
			28,040.95
	Tax		2,453.58
1	Typical installation	1,056.00	1,056.00
1	Training	500.00	500.00
	<b>Total</b>		<b>32,050.53</b>



# 5 Year Plan

